

# C SERIES



## OPERATION AND MAINTENANCE MANUAL

C-150, C-250, C-375, C-500, C-800



Model:  
By SteelTech Inc.  
Version 2

Serial No.:  
UL 2523-2009  
UL 391 (1995)  
CAN/CSA B366.1-M91



# Contents

## Warranty and Safety

Limited Lifetime Warranty . . . . . 4  
 Water Treatment And Testing . . . . . 5  
 Water Treatment Policy . . . . . 5  
 Safety Precautions . . . . . 6  
 Chimney . . . . . 7

## Installation

Location . . . . . 7  
 Furnace Foundation . . . . . 8  
 Trench . . . . . 8  
 Wiring . . . . . 9  
 Hydronic Lines . . . . . 9  
 Furnace Connection . . . . . 9

## Operation

How it Works . . . . . 12  
 Filling The Furnace With Water . . . . . 12  
 Firing The Furnace . . . . . 12  
 Care And Maintenance . . . . . 14  
 Troubleshooting . . . . . 15  
 Electrical Schematics Ranco Control . . . . . 17-18  
 Electronic Temperature Control Settings &  
 Specifications . . . . . 19  
 Electronic Timer Control And Settings . . . . . 20  
 Unit Footprints . . . . . 21  
 Replacement Components List . . . . . 22

**RETAIN THIS MANUAL FOR  
 FUTURE REFERENCE  
 DO NOT THROW AWAY**

### CANADA

SteelTech Inc.  
 Box 158  
 Winkler MB. R6W 4A5  
 Canada  
 Ph. (204) 325-9792  
 Fax (204) 325-9803

### USA

SteelTech Inc.  
 Box 373  
 Walhalla ND. 58282  
 Ph. (877) 325-9792  
 Fax (204) 325-9803

info@heatmasterss.com  
**www.heatmasterss.com**

# LIMITED LIFETIME WARRANTY

SteelTech Inc. warrants to the original owner of the Heatmaster<sup>SS</sup> outdoor furnace that it is free from defects in workmanship and material which could cause a leak or malfunction of the firebox or water jacket and against corrosion (if the instructions in the owner's manual for water treatment and maintenance are followed) for The Life of the furnace toward the purchase of a new Heatmaster<sup>SS</sup> furnace, in the following pro-rated schedule.

**Warranty schedule:** coverage in the initial 5 years is 100%

- Year 6-7 is 50%
- Year 8-9 is 40%
- Year 10-15 is 30%
- Year 16-Life is 10%
- Grates and Firebox door have a warranty of 5 years at 100%.
- Ash Pan is covered for corrosion protection for a period of one year.

In addition, all steel components including housing, legs, etc. have a pro-rated warranty for a period of 10 years with coverage reducing by 10% per year. Any parts not manufactured by SteelTech Inc. that are used on the furnace such as fans, aquastats, limit switches, pumps, heat exchangers, etc carry their own manufacturer's warranty, normally one year. SteelTech Inc. will not be liable for the cost of shipping, labor, replacement or repair of these parts.

If warranty requires removal or replacement of the furnace or a part of the furnace, SteelTech Inc. and their dealers are not responsible for the cost of labor, replacement of antifreeze or water treatment, shipping

cost or any other cost other than the replacement component or furnace. SteelTech Inc. always has the right to decide if a part or furnace will be repaired or replaced and will not be liable for any cost not authorized by a SteelTech Inc representative.

SteelTech Inc. does not warranty any damage caused due to burning improper fuels such as wood, oils or plastics, negligence and deterioration due to lack of proper ongoing maintenance, physical damage caused by abuse or freeze up, power surges or unauthorized work or modifications to the furnace. It is recommended to always have a back up heating system installed in case of disruption in the outdoor furnace heating system.

SteelTech Inc. is not liable for any damage or cost which may occur from or during the operation of the furnace or damage incurred due to any heating system failure. The purchaser assumes all responsibility for the care, maintenance and safe operation the furnace including adding of approved boiler treatment or water. SteelTech Inc doesn't warrant door gaskets, exterior paint or finish.

To qualify for warranty all instructions must be followed in operator's manual, **water must be tested and maintained a minimum of once per year**, and warranty registration must be on file at SteelTech Inc within 30 days of purchase along with a copy of the original invoice. **No warranty can be approved unless the warranty registration and water test verifications are on file at SteelTech Inc.'s office.**

SteelTech Inc. reserves the right to change conditions of warranty at any time.

# WATER TREATMENT AND TESTING

## Water Treatment Policy

To qualify for warranty, water must be tested a minimum of once per year and water treatment added when necessary.

### To take a water sample:

1. Locate your water sample bottle, mailing carton and mailing label provided to you by your dealer.
2. Open the boiler drain located at the bottom of the rear of the furnace for 10-15 seconds or until the water runs clear. **CAUTION:** Water is hot! Use extreme care or a bucket to run water into and let cool before collecting sample.
3. Fill one of the test bottles at least 1/2 to 2/3 full.
4. Fill out the mailing label provided with the test bottle completely, including your email address, the model number and serial number of your furnace. Make sure to note if the furnace water contains any antifreeze or additional chemicals.
5. Attach top part of label to sample bottle and bottom part to outside of mailing tube. Place bottle in tube.
6. Mail to our testing lab. Results can take up to 4 weeks to receive and up to 8 weeks if no email address is on hand at Heatmaster<sup>SS</sup>.

You will receive a water test report outlining what must be done (if anything). If any action is necessary, take another sample and mail it to our test lab again to verify the recommended changes have been made.

Add the water treatment through the fill pipe located at the top of the furnace when initially filling the furnace with water or after testing, if needed. Ensure that all drains are closed. It is recommended that water treatment is added at a 1:200 ratio when initially firing the furnace, and add accordingly based on the water test results. Additional treatment may have to be added for water with more severe properties or for systems with more chemically demanding requirements.

**Recommended operating levels are as follows:**

**Conductivity:** 100 - 4000 ppm

**pH:** 8.5 - 10.5

**Nitrates:** no less than 730 ppm

## Test Parameters and What They Mean

### Conductivity

Conductivity is a measurement of minerals in your furnace water. While it is common to have minerals in water, in excess minerals can cause many problems in hydronic systems including scaling and corrosion.

### pH

pH is measurement of alkalinity (hard or soft water). For outdoor furnace water and the water treatment used in outdoor furnaces it is better to have your water a little harder than softer (recommended pH range is 8.5-10) as the active ingredients in the water treatment neutralize harder water easier than softer water

### Nitrates

Nitrates tested for are a measurement of how much water treatment is in the water. Nitrates measured are active units of water treatment available to neutralize harmful elements in your furnace water. Nitrates also act to neutralize harmful bacteria that may build up in the furnace water over time.

### Glycol

Inhibited glycol provides anti-corrosion elements and freeze protection for outdoor furnaces and is compatible with Outdoor Furnace Water Treatment. Because outdoor furnaces are open to the atmosphere systems and will have fresh water added occasionally, oxygen is always entering the system and will break down the glycol over time to create glycolic acid which will harm your furnace system. When this happens you will be required to drain and flush your furnace system.

It is always suggested to use 100% virgin glycol instead of recycled glycol as it will break down much sooner and create glycolic acid.



# SAFETY PRECAUTIONS

Read and understand all precautions before operating the furnace.

**Save these instructions. Retain this manual as long as you own your Heatmaster<sup>SS</sup> furnace. Carefully read and follow these directions.**

## IMPORTANT

**THESE FURNACES ARE FOR COAL BURNING ONLY. Follow all applicable local laws.**

## DANGER

Do not start fire with or burn chemicals, volatile fluids, rubber, plastics or garbage. Only competent persons with a sound understanding of this heating method should operate this furnace. Improper firing could result in personal injury and or damage to the unit and void warranty.

### Risk of fire or explosion

- Do not use chemicals or fluids to start the fire.
- Do not burn garbage, gasoline, drain oil or other flammable liquids.
- Do not operate with fuel loading or ash removal doors open
- Do not store fuel or other combustible material within marked installation clearances
- Inspect and clean flues and chimney regularly
- Maximum draft marked on nameplate
- **DO NOT CONNECT THIS UNIT TO A CHIMNEY FLUE SERVING ANOTHER APPLIANCE**

## WARNING

- All installations and operations of your HEATMASTER SS product must follow STATE, PROVINCIAL, and LOCAL LAWS pertaining to operations, wiring, plumbing and building codes.
- All models operate at atmospheric pressure. DO NOT obstruct, block or plug the overflow vent tube in any way which is located on top of the boiler either in front of or behind the chimney.

- When installing the furnace, the chimney should never be connected to a chimney flue serving another appliance.
- Do not start a fire in the furnace without first filling with water. It will cause serious damage to the furnace.
- All covers or guards must be in place at all times, except for maintenance or service.

## ATTENTION

- A copy of the owner's manual in French is available by request from Heatmaster<sup>SS</sup> offices.
- The person(s) operating this furnace must comply with all applicable local and state laws or other requirements,
- Do not remove labels from furnace except in the case of servicing.

## CAUTION

- Use of an approved spark arrester is recommended. It is the recommendation of SteelTech Inc that a 15' minimum distance of clearance from buildings and other combustibles. Your local authorities and your insurance company may require a greater distance. Never allow combustible material to accumulate near the unit. Fuel should never be stored where there is the potential for accidental fire.
- Load carefully or damage will result.
- Do not use chemicals or fluids to start the fire.
- Do not start or operate furnace without checking heating fluid. Furnace must be filled until heating fluid comes out of vent pipe on the top of the furnace.
- **Hot Surfaces:** Keep children away. Do not touch during operation.

## RECOMMENDED

Choose the location of your furnace with concerns of wind direction, smoke odor, sparks, blocked viewing and fuel storage carefully. Be a responsible and considerate owner.

## Chimney

The chimney on your HeatMaster<sup>SS</sup> outdoor furnace is a stainless steel double wall insulated chimney. It is attached to the furnace with a stainless steel adapter. To install chimney extensions be sure to purchase the same chimney as on your furnace (Selkirk Ultra Temp). These chimneys are a twist lock connect chimney. Be sure to use the chimney fastening ring to fasten the connection tight. Braces, elbow kits and roof flashing kits are available through your dealer. It is not recommended that the chimney be longer than 15 ft.

Do not connect this unit to a chimney flue serving another appliance.

The chimney and flue pipe need to be kept clean and in good condition. See below for chimney sizes.

- **C-150** - 6" Stainless Steel Double Wall Chimney and Adapter

- **C-250** - 6" Stainless Steel Double Wall Chimney and Adapter
- **C-375** - 6" Stainless Steel Double Wall Chimney and Adapter
- **C-500** - 8" Stainless Steel Double Wall Chimney and Adapter
- **C-800** - 10" Stainless Steel Double Wall Chimney and Adapter

**NOTE:** Chimney extensions and caps are useful for lifting exhaust gases and smoke away from buildings. However, when burning a C Series furnace keep in mind that the cooler exhaust temperatures as a result of the high efficiency burn of these furnaces may cause excess condensation when chimney extensions and caps are used. This can lead to improper burning in the furnace. A taller chimney also greatly increases the risk of overheating due to the extra draft created caused by the negative pressure put on the firebox. Extra care must then be taken to minimize air leakage into the firebox.

---

## FURNACE INSTALLATION GUIDE

Installation should be performed by a qualified technician. THESE FURNACES ARE FOR COAL USE ONLY.

FOLLOW ALL APPLICABLE LOCAL LAWS

### LOCATION

Maintain adequate clearance of buildings and combustibles. Store fuel outdoors under cover. Do not place or store fuel or allow debris to accumulate within stove installation clearances or within the space required for charging and ash removal. Never install the furnace in the fuel storage building.

Contact all governing authorities in your area prior to installation.

When choosing the location of your furnace you should consider prevailing wind direction, distance from home for refueling and fuel storage and give consideration for any effect on your neighbors.

## FURNACE FOUNDATION

- Inspect the ground conditions that you intend to install your furnace on. If the area is unstable or has a history of staying wet you may have to improve the soil with gravel as well as raise the level of furnace placement.
- A cement pad of 4-6" in thickness should be used.
- The furnace in most cases can be placed on 4 cement blocks not less than 6" wide X 10" long and 3" thick.
- The furnace should never be installed on a combustible floor.
- Never allow combustible material to accumulate on the furnace foundation.
- Do not install on a combustible base

**Find the footprint of the furnace you have purchased in the appendix of this manual** and place your blocks so the legs will stand on the center of the blocks. Cement pads should be a little bigger than the actual furnace, with about a 4' extra length front and back so you have a solid working area.

## TRENCH

SteelTech Inc recommends the trench to be 24" to 36" deep and wide enough to install your water lines. Take into consideration soil conditions as rocky soil conditions can cause the casing of the pipe to be damaged and allow water to fill the pipe. If soil conditions require, fill the trench with sand.

If possible, have a gradual slope in your trench to allow drainage away from your lines and out of trench bottom. Most insulated underground pipe has room for electrical wire in it. If it does not, place electrical supply in bottom of trench and cover with 6 inches of dirt. A minimum of R8 insulation value is recommended and a water tight vapor barrier such as PVC pipe or drain tile to encase your insulation is a must.

**NOTE:** It is recommended that only high quality, well insulated lines are used. Poor quality casing or insulation can deteriorate over time causing heat loss in the ground and loss of efficiency in your system. Purchase your insulated line from a reputable source. Your Heatmaster<sup>SS</sup> dealer will carry high quality insulated line and can help you determine the best line to purchase.

**NOTE:** If you are installing your water lines under an area where vehicles will cross, you should increase your depth of the trench and use a schedule pipe over your lines to reduce the pressure generated on the lines.





## WIRING

All wiring must conform to local codes. Use an electrical wire rated and approved for underground installations. **This wiring can be placed in the same trench below the water lines.** It is recommended that a qualified technician be present when installing the electrical portion of the hook-up.

See Pages 17-18 for the furnace wiring diagrams.

## HYDRONIC LINES

Hydronic lines (hot water heating lines) whenever buried or encased in cement should not be spliced. Take the necessary steps to ensure they stay dry. This ensures that minimal heat loss occurs. Supply and return lines should be a minimum of 3/4" diameter, although 1" is most common, and have a rating of 100 PSI capacity at 180 degrees Fahrenheit. This pipe should be listed for potable water.

**Hint:** Mark your feed and return lines prior to covering and allow enough pipe above ground at both ends for a relaxed connection. Red lines are generally "hot" while blue are usually "cold".

## FURNACE CONNECTION

Connections to the furnace are clearly marked.

Return (from the building) are the top ports, Supply (to the building) are the bottom ports. The installation of isolation valves at both ends of the pump is recommended as well as a valve at the return line. This will allow you to shut off water supply if repairs

or additional heating components are added to the system. Your main power is connected to the junction box at the back of furnace and should be connected by a qualified technician.

**NOTE:** A supply of fresh air is necessary for combustion and ventilation. Do not block fresh air intake located at the back of the furnace.

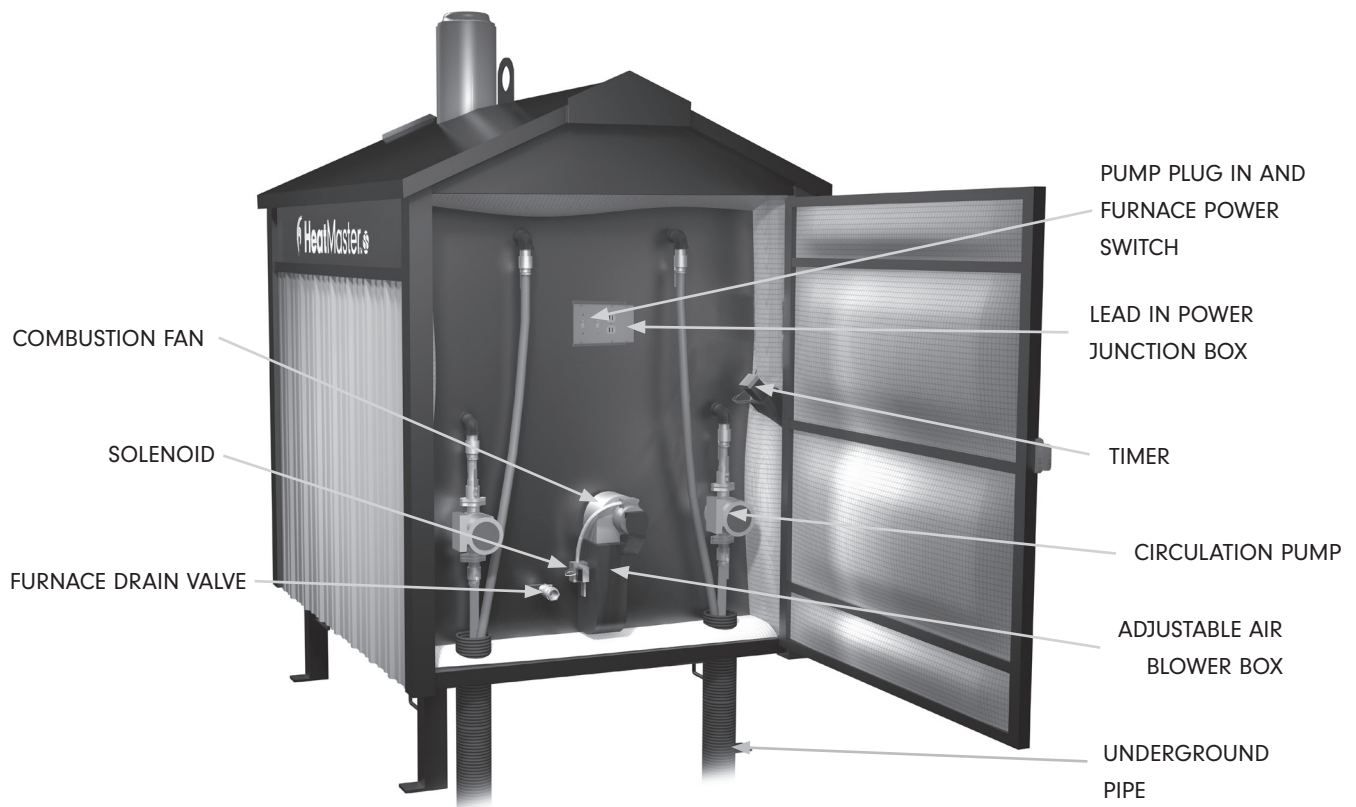

At least one pump must be circulating at all times or the water in the furnace may boil. A continuous pump is also useful for freeze protection in temperatures below 32 degrees F.

It is important to calculate the BTU's needed, line size, flow rate and return water temperature to determine what size circulating pump is needed. Undersized lines or long distance piping can reduce flow dramatically.

The best place to mount the main pump is on the supply outlet. Placing the pump inside the building can lead to cavitation and air-lock problems.

### Building Connections

A hole large enough to accommodate the water lines, insulation and PVC piping through is important. Attention to sealing this point with a weather proof insulation on both sides is also important.

### Interior Connections

You may require either a water-to-water (tube and shell or plate) or a water-to-air exchanger (rad) to transfer heat energy from the hot water your furnace has produced. Your plumber or dealer can design and install a system to best fit your needs.

**IMPORTANT:** It is recommended to always have a back up heating system installed in case of disruption in the outdoor furnace heating system.

The following are examples of basic interior connections. SteelTech Inc. carries the necessary parts for installation. Contact us for more information!

**DISCLAIMER:** The following information in the interior connections are examples and suggestions only. When installing a furnace and its parts it is best to talk to your local dealer or a qualified technician.

### Water-To-Water Heat Exchangers

To maintain pressure in an existing boiler while using an outdoor furnace a water-to-water heat exchanger is used. The water-to-water exchanger is installed in-line on the return side of the existing pressurized boiler system.

- Operate the (gas, oil, electric) boiler periodically to ensure that it will operate satisfactorily when needed.

- Do not relocate or bypass any of the safety controls in the original (gas, oil, electric) boiler installation.
- The operation of the gas boiler must be verified for acceptable operation before and after installation of the add-on appliance by a gas fitter who is recognized by the regulatory authority.
- Do not connect to any chimney or vent serving a gas appliance.

The installation should comply with requirements of CAN/CSA-B365, and changes to the installation should comply with CSA B139 (for oil-fired), C22.1 (for electric), or CAN/CGA-B149.1 or CAN/CGA-B149.2 (for gas-fired).

Any installation of an add-on boiler shall:

- be installed without interfering with the normal delivery of heated water from the original boiler,
- be installed without affecting the operation of the electrical and mechanical safety controls of the original boiler,
- provide for a changeover from one fuel to the other without requiring manual adjustment of any controls or components other than the thermostats,
- have provisions for preventing, or adequate water capacity within the boiler to prevent damage from loss of circulation due to electrical power failure,
- be installed without changing the function of the controls or rewiring the original boiler. A wiring interconnection is permitted. The electrical system of both boilers shall be powered from a single branch circuit without exception.

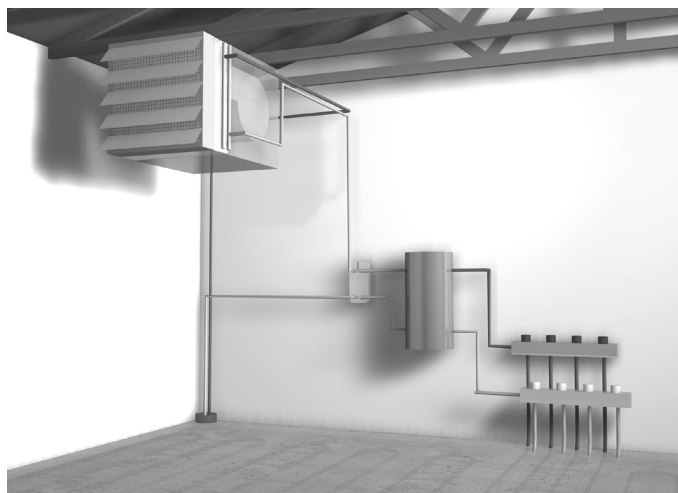

Heat exchanger with boiler

## INTERIOR CONNECTIONS (continued)

When circulation is reduced because of an electrical power failure the installation of a hot-water circulation loop that will dissipate at least 10% of the estimated rated heat output of the solid-fuel boiler is recommended with the following guidelines:

- The loop can only be made inoperative by a deliberate manual action.
- The design parameters for sizing shall be a pipe size > 3/4 inch (18 mm), room temperature of 65° F (18° C), and mean water temperature of 180° F (82° C).
- The loop be positioned above the boiler, with features that promote natural thermal circulation of the water.

The piping used in the system should not cause any restrictions that could create excessive pressure in the system. Eg. Reducing from 1" pipe to 1/2" pipe

## Flat Plate Exchanger For Pressurized Systems

Flat plate exchanger systems that are used with pressurized systems such as in floor heating or hot water baseboard systems help to heat the water going in to the pressurized system while keeping the two systems separate. Because an outdoor furnace is an open system (not pressurized) and the system tied in to in this type of application is pressurized it allows both systems to stay the same while being operational.

The water supplied by the outdoor furnace will heat the water in the pressurized system while the present heat source in the pressurized system (such as a boiler) can be used as a back up heat source in case of emergency or need for additional heat.

## Domestic Hot Water

Flat plate exchanger systems used to pre-heat domestic water tanks are generally easier to install, more efficient and more reactive to hot water demands than tube and shell (sidearm) systems. They are mounted on the supply line and pre-heat the water going in to the hot water tank.

## Forced Air Furnace (Water-To-Air Exchanger)

The water-to-air heat exchanger must be mounted so that air blows through the fins (coils). The exchanger should be mounted below the A/C coil if possible. The exchanger should be sized to fit existing duct work and should produce about as many BTU's as the existing heat source. An exchanger that produces too many BTU's will result in uneven heat and the fan stopping too quickly while a heat exchanger that is undersized will not produce the necessary BTU's.

On systems with Air Conditioning it is very important to not restrict airflow as it will cause the freon coil to freeze up. Using standard outdoor furnace 3 row coils, a minimum of 80 sq. in. of coil should be used per ton of cooling. Exchangers can be mounted in cold air returns but greater care must be taken as heat from the exchanger can interfere with the air handler controls and/or sensors.

It is important that the warm-air supply-duct system be constructed of metal in accordance with NFPA 90B-1993, 2-1.1 if the outlet-air temperature of a central furnace exceeds 250° F (121° C) when it is tested in accordance with the requirements for Simultaneous Firing in 56.4.1 and 56.4.2 of the standard. It is also important that the plenums installed to the furnaces be constructed of metal in accordance with NFPA 90B-1993, 2-1.3.

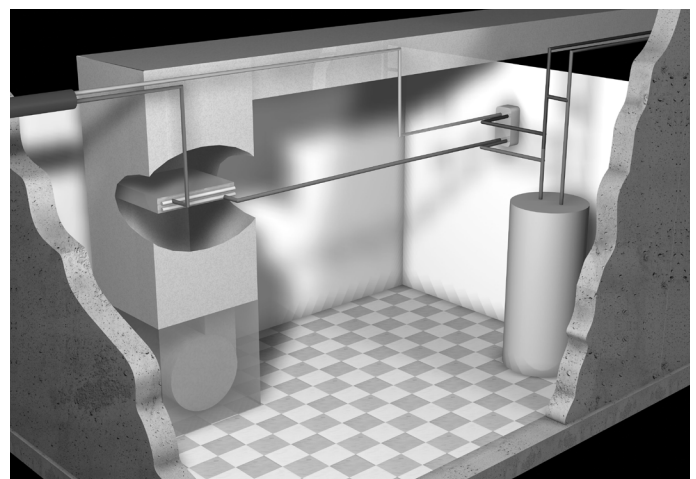

Forced air furnace with water-to-air exchanger

# OPERATING THE FURNACE

## HOW IT WORKS

The C Series furnace is a 409 stainless steel outdoor furnace with a water jacket surrounding the firebox. This reservoir of hot water is pumped through insulated lines to buildings, pools, greenhouses or whatever is being heated.

Fuel is loaded in the firebox and the aquastat senses the water temperature, sending power to the solenoid and draft fan when the water temperature gets too low.

When the furnace calls for heat, the solenoid opens the draft flap in the blower box and the fan blows air through the box and under the grates cooling them even during a hot burn.

The majority of the air enters the firebox through the grates and coal bed creating a very hot burn but some also is forced up through the secondary air vent. This helps burn off the gases, increasing efficiency and reducing smoke.

After leaving the top of the firebox the exhaust is forced to scrub the water jacket while traveling through the curved baffle, then goes up through water jacket, impacting the top bypass baffle, traveling all the way to the front, then to the back and up the chimney. This triple pass is a simple and very effective heat exchanger, lowering exhaust temperatures and also extinguishing sparks as they travel back and forth over the long distances. The C800 model utilizes a double instead of a triple pass.

When the aquastat senses the water is up to the high temperature setting, it shuts off the fan and the solenoid drops.

The furnaces is normally loaded every 12-24 hours and ashes are removed when needed using the ash rake, shaker grate and ash pan.

## FILLING THE FURNACE WITH WATER

Your furnace has a vent pipe that protrudes through the roof and contains the water level float indicator. The float level can vary an inch or so depending on the water temperature. Add water when it reaches half way down the gauge. Allowing the furnace to run low on water will cause the furnace to overheat and

cause damage to the furnace. It can also potentially cause a fire hazard. This is an open system so the unit cannot be pressurized. If you overheat and boil the water in the furnace immediately refill the tank, then try to find the source of the problem.

**Hint:** Although water can be filled using the vent pipe, it is recommended that a fill valve be installed inline in the building you're heating with a one way check valve to prevent back flow. Filling the furnace with the inline valve pushes all the air towards the furnace and out of the vent. Because this furnace is an open system it is normal that water will have to be added annually.

**CAUTION:** Do not fire furnace until it is filled with water. Allow furnace to run for 2 days and check system water levels and fittings for leaks. Add water treatment and take your initial water sample at this time and be sure that it is sent in to Heatmaster<sup>SS</sup> offices for testing.

## FIRING THE FURNACE

These furnaces have been specifically designed to burn coal and as such, are not intended for burning any other fuels such as wood, rubber, oil, plastic or garbage. Burning these fuels in your furnace will result in the warranty on the furnace being voided.

**It is a violation of the 2015 EPA New Source Performance Standards for Residential Heaters to burn unapproved fuel in this outdoor furnace**

### WARNING - Risk of Fire

- Do not operate with fuel loading or ash removal doors open.
- Do not store fuel or other combustible material within marked installation clearances.
- Inspect and clean flues and chimney regularly.

### CAUTION - Hot Surfaces

Keep children away. Do not touch during operation.





## Coal

When initially firing add a small amount of paper and wood kindling to start the fire and create a coal bed. Once a sufficient coal bed has been developed, add coal gradually until a suitable fire is achieved then add coal as needed to bring up the fire.

Load the furnace twice a day

**ATTENTION:** On the initial start up the water jacket will reach what is called the dew point. This creates a sweating inside the fire box and water to collect in the ash drawer and on the door jamb which may last a couple of days and is normal.

**Hint:** Although everyone has different methods of firing, it is worth mentioning that adding and filling your furnace to capacity reduces the efficiency of the furnace. It is better to load twice a day with less fuel than once a day filling to capacity. Smaller fuel loads burn hotter, cleaner and more thoroughly. By burning off more of the gases (smoke), you enhance the overall efficiency of your system and increasing heat transfer to the water.

Coal varies widely depending on the type of coal and properties of the seam that it was mined from (ash content, clinkering, BTU output, etc.). Some adjustment in firing methods such as banking the coal differently, adjusting the timer settings, varying the amount of coal loaded, etc is normal because of this. If you experience difficulty after trying different methods, it may be helpful to try coal from a different source.

**CAUTION:** Be very cautious when opening the firebox door to refuel. Coal generates very explosive gases and opening the firebox door introduces oxygen that can cause the gases to flash. Always turn off the draft fan (Furnace On/Off Switch on Control Panel) and open the door to the second latch point to allow it to vent the gases for at least 15 seconds. Only open the door up when you are sure it is safe to do so, keeping your face and body well away from, below and behind the door.

Only open the door long enough to refuel. A door left open too long can cause the fire to flame up, endangering yourself and damaging the furnace.

## Loading

1. Once a hot coal bed is established, load a deep pile of coal towards the back of the firebox no higher than the bottom edge of the door jamb.
2. Be sure to leave a small air hole at the front of the pile (near the secondary air vent) to maintain enough airflow up through the grate.
3. Load only what you need for the next 12-24 hours as overloading the furnace is much less efficient.
4. DO NOT pile coal above the bottom edge of the door jamb. It will choke out the draft and sporadic flashing may occur.

## Cleaning and Removing Ash and Clinkers

Occasional breaking up of the crust that forms on top of the fuel load may be needed. When the pile burns down, stir the pile and shake the grates just enough to let the fine ash fall through.

Do not try to force all the clinkers through the grate as it may cause it to jam. It is better to allow some to accumulate, let the fire to burn down, and lift them out the door with a shovel. Too many clinkers can cause the fire to slow down and choke. If clinkers accumulate too quickly you may have poor quality coal.

Allowing a small amount of ash to accumulate on either side of the grate will keep the fire lit better on mild days, but be sure to keep the center of the grate open so the burn rate is correct.

Always empty the ashes after shaking them down. If any hot coals are shaken down they can ignite when the draft comes back on and create a super-heated environment in the ash pan. This can cause the ash pan and grates to warp and is not covered under warranty. Always lift the ash pan slightly as you slide it in so the front edge scrapes the ash box clean. This will keep the pan level and prevent air leakage. Be sure ash pan is closed tightly before you leave.

Some coal smolders better during off cycles than others. Shortening the differential on the Ranco temperature control to make it cycle more often can help but is a less efficient burn.

Cleaning any ash in the bypass baffles is important. Ash or creosote buildup can slow the burn rate and reduce heat transfer to the water. The curved baffle inside the firebox can be swept forward into the



firebox. It can also be removed by bending the tabs on the front right and left corners down and sliding it forward. The top bypass divider can slide completely out which will give plenty of room to drag any ash forward and out the top clean-out door (there is no divider in the C800 model). Be sure to replace it right-side up as it will not allow airflow through upside down. If wet creosote accumulates in the top of the chimney the burn rate is probably too slow and adjustments in loading, burn times or burn rate may be necessary to prevent the furnace airways from becoming blocked.

## CONTROLS AND SAFETY DEVICES

**Furnace Control** - Your Heatmaster<sup>SS</sup> C Series furnace uses a factory-programmed aqua stat control to maintain your water temperature by lifting a solenoid to open the air way and engaging the draft fan. The control is located around the corner to the left of the firebox door and displays the water temperature in your furnace. Programming and troubleshooting instructions can be found on page 20 of this manual.

**Solenoid** - The solenoid is located beside the black metal airbox mounted on the rear of the furnace and is a mechanical part that opens or closes the air injection port. The solenoid should lift when the furnace is calling for heat and lower when the furnace has reached its desired temperature.

**Draft Fan** - The draft fan is located at the rear of the furnace on top of the black metal airbox and is used to inject air in to the furnace. The fan should be on whenever the furnace is calling for heat.

**Timer** - The timer is located in the rear of the furnace near the lead in power box. It can be set using the instructions on page 21 of this manual to turn the draft fan on in set intervals to keep the coal bed alive during times of idle.

**High Limit Switch** - The high limit cut off switch is used to ensure the furnace does not cause damage via runaway fire. It acts as a safety switch by cutting power off to the fan if the water temperature rises above 190° F.

---

## CARE AND MAINTENANCE

To obtain the high levels of performance of your furnace, certain maintenance procedures are required periodically to avoid soot, creosote and ash buildup.

**On a daily basis** you need to:

- Check for ash and creosote buildup until experience shows how often cleaning is necessary.
- Remove ashes.
- Ensure that the door gasket is sealing properly.
- Ensure that door and ash drawer are closed and sealing properly.
- Check water level.
- Check for sparks or coals that may have fallen from the furnace and make sure they are safely disposed of.

**On a weekly basis** you need to

- Check for ash and creosote build up in the bypass trough, top heat exchange chamber and chimney. Fly ash should be removed to allow free airflow through the furnace. An ash choked furnace flue will reduce the burn rate and create poor heat transfer.

- Removal of creosote may be necessary in mild weather. Burning your furnace with a larger differential at higher temperatures means less creosote buildup.

**On a seasonal basis** when furnace is not in use, you will have to:

- Remove all ashes and excess creosote.
- Inspect the firebox for leaks and any other possible problems.
- Clean out bypass trough and chimney.
- Cover chimney and crack open the ash pan door enough to allow air movement and reduction of condensation within the fire drum.
- Have your water treatment tested and adjusted to manufacturer's specifications. See page 5 for exact specifications.
- Change your water filter cartridge and inspect all of your system for leaks.
- Tighten your firebox door by adjusting the hinges on each side of the door.

- Cleaning of the heat exchanger, flue pipe, chimney and draft inducer if used, is especially important at the end of the heating season to minimize corrosion during the summer months caused by accumulated ash.

### Creosote and Fly Ash Formation and Need for Removal.

**ATTENTION:** Have a clearly understood plan to handle a runaway fire or chimney fire

When coal is burned slowly, it produces tar and other organic vapors, which combine with expelled moisture to form creosote. The creosote vapors condense in the relatively cool chimney flue of a slow-burning fire. As a result, creosote residue accumulates on the flue lining. When ignited, this creosote makes an extremely hot fire. The chimney and chimney connector should be inspected at least twice monthly during the

heating season to determine if a creosote buildup has occurred. If creosote has accumulated it should be removed to reduce the risk of a chimney fire.

**Disposal of Ashes** - Ashes should be placed in a metal container with a tight fitting lid. The closed container should be placed on a non-combustible floor or on the ground well away from all combustible materials before final disposal. If the ashes are disposed of by burial in soil or otherwise locally dispersed, they should be retained in the closed container until all cinders have thoroughly cooled.

**CAUTION:** Make certain that all electrical power to the furnace and components is shut off. It can be washed using water and a mild non abrasive cleaner suitable for painted surfaces.

**ATTENTION:** Avoid direct water pressure to electrical components and connections.

## TROUBLESHOOTING

### If the furnace is running but fails to bring water up to temperature:

1. Check fire.
2. Check fan for operation.
3. Check that the solenoid damper and fanbox elbow is open to allow air injection.
4. Check to ensure the furnace is sized accurately according to heat demand.
5. Check fuel type. Poor quality fuel will not provide as many BTU's as high quality fuel.
6. Check water level of furnace.
7. Check for ash and creosote blockage at chimney and bypass trough.
8. Check temperature settings. Make sure high temperature setting is set to at least 165 F.
9. Check for power at furnace.
10. Check to ensure all pumps in the system are running.
11. Check to make sure there are no leaks, hot/wet spots on your ground or breaks in the pipe or fittings which may cause the pipe to be saturated and lose its insulation value.

12. Check Temperature of water exiting furnace, entering the building being heated and before and after each heat exchanger.

### If the furnace water is hot but buildings do not have heat:

1. Check to ensure all pumps in the system are running.
2. Check filter cartridge for flow blockage (if installed).
3. Check for air in the system at the exchanger by bleeding off.
4. Check for closed valves to ensure water flow.
5. Check Temperature of water exiting furnace, entering the building being heated and before and after each heat exchanger.

### If the furnace overheats:

1. Check that all doors are closing properly and that door gasket is completely sealing.
2. Check that the solenoid damper plate is opening and closing without hang-ups.
3. Check venting and fan box on rear of furnace for air leaks.

4. Check that the temperature settings are correct. The furnace should be set on Heating Mode (H1) and the high temperature setting should be set no higher than 185° F.
5. Check chimney draft. If the chimney has been extended too far or has a strong wind blowing over it, it may cause a draft down the furnace.
6. Check water level.
7. Make sure the door and ash drawer are air tight.
8. Check to ensure all pumps in the system are running.

**If the furnace has shut down:**

1. Check to ensure that the unit has power (does the light work?).
2. Check to ensure the Furnace On/Off switch is in the On position.
3. Check the water temperature (furnace has a high temperature cut out of 190 degrees F. and turns on again at 140 degrees).

**If there is a chimney fire:**

1. Make sure the firebox and ash pan doors are tightly closed.
2. Close all combustion air inlets on the furnace.

**If there is a power failure:**

1. Open all flow-check and zone valves in the system. Depending on the system design, this may allow convective circulation. **NOTE:** This does not apply to gravity systems, as they have no flow-check valves and will continue to operate normally without electricity.
2. It is important to remember that the heating systems cannot dispose of a great deal of heat without the circulator(s) running. Avoid over-firing! **DO NOT LOAD LARGE AMOUNTS OF SOLID FUEL INTO THE FURNACE!** Fire the furnace cautiously until you are able to determine how quickly the heat system is able to absorb the heat being produced by the furnace.
3. When the power has returned, reset all flow-check and zone valves and resume normal operation of the system.

**If there is smoke leaking out of the door.** Small amounts of smoke leakage is normal due to the fan pressure and restricted exhaust.

1. Check to ensure door is sealing properly.
2. If the seal is worn out it will have to be replaced.
3. The door may need to be adjusted. To do this loosen the Door Latch Bearings and Door Hinge bearings and set the door so it seals tightly against the door jamb.

**If the furnace has an excessive amount of creosote either in the firebox or in the bypass**

1. Check to ensure the furnace is sized accurately according to heat demand. If the furnace is oversized it will idle and cause this. If the weather is warm or mild burn a small hot fire keeping only enough fuel to last until your next burn time (generally 12 hour burn time is best). It will allow the furnace to burn more often with greater efficiency and have less fuel smoldering during idle, creating less creosote.
2. If the chimney and/or bypass become plugged with creosote it will be necessary to scrape the creosote out to obtain a proper burn in the firebox.

**Having to fill the furnace with water more than once a week or more than a few gallons of water per week and there is no obvious explanation**

1. Check the temperature settings and gasket on the door and ash drawer to ensure the furnace is not over temperature and steaming. If water temperature reaches levels over 200 degrees Fahrenheit the water will steam and water loss will occur.
2. Check the perimeter of the furnace for water puddles collecting or dripping from the furnace. If water is found open the rear door panel and search the floor to find the source of the water.
3. Check all plumbing in the system to ensure there are no leaks.

**The Ranco Temperature control is giving the user an error message.**

Instructions for dealing with Ranco ETC settings and error codes are included in the owner's manual on page 20.

C-150, C-250, C-375  
Electrical Schematic Ranco Control

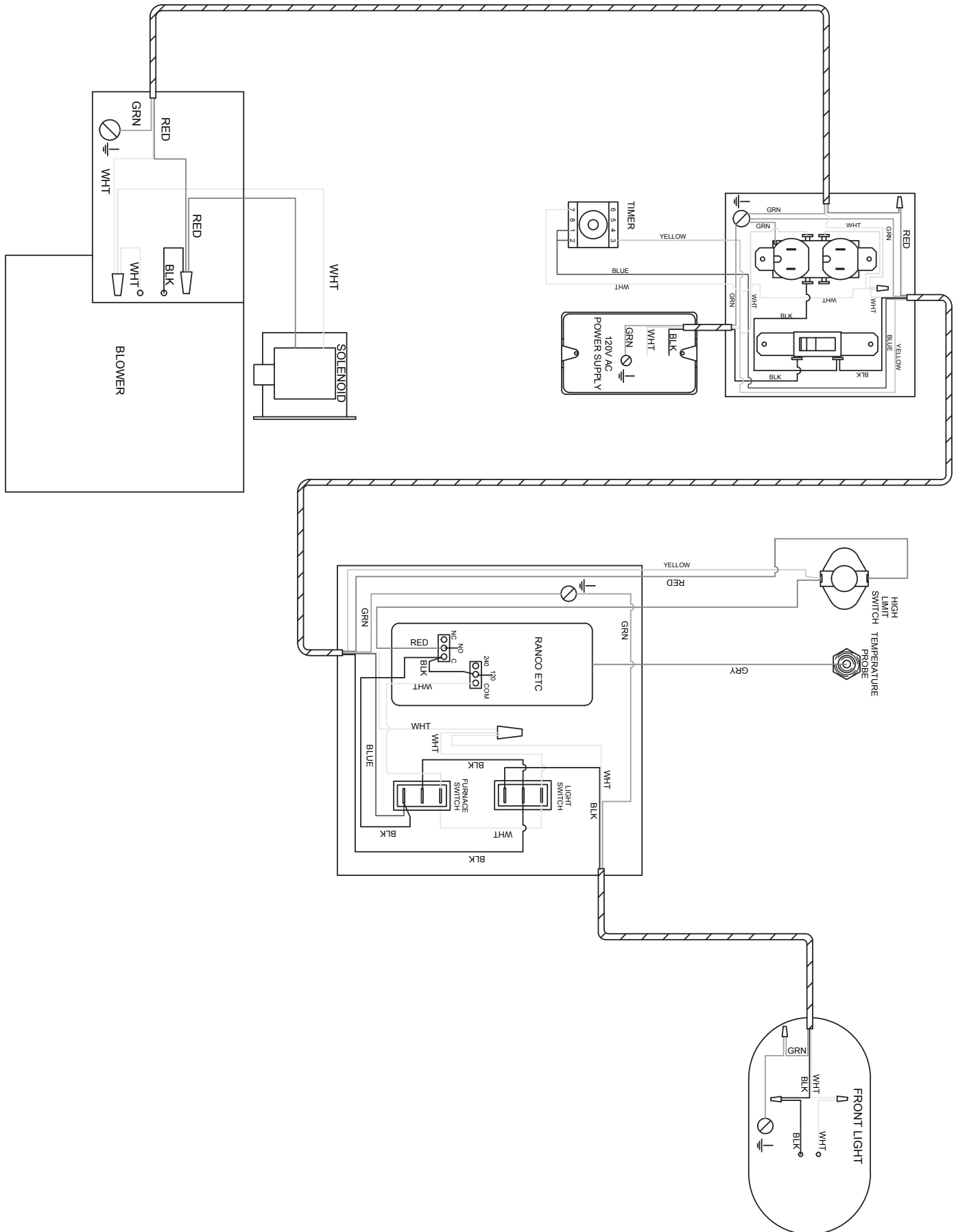

# C-500, C-800

## Electrical Schematic Ranco Control

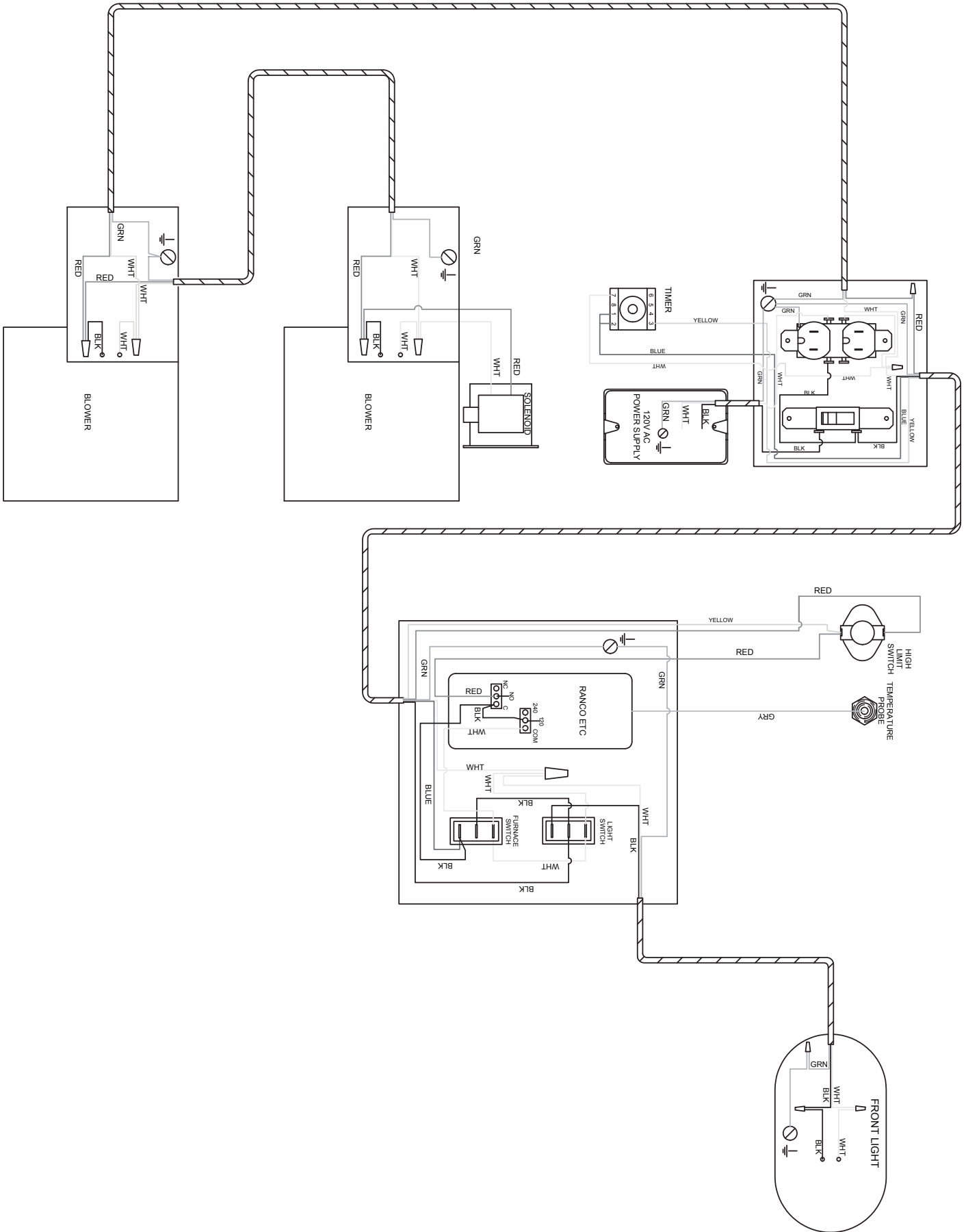



## Electronic Temperature Control Settings & Specifications

### Description

The Ranco electronic temperature control (ETC) is designed to provide on/off control for heating and cooling. It is equipped with a liquid crystal display (LCD) that provides a constant readout of the sensed temperature, and a touch keypad that allows the user to easily and accurately select the set point temperature, differential and heating/cooling mode of operation.

### Programming steps and Display

The ETC can be programmed in four simple steps using the LCD display and three keys on the face of the control.

**STEP 1** To start programming press the **SET** key once to access the Fahrenheit/Celsius mode. The Display will show the current status, either F for degrees Fahrenheit or C for degrees Celsius. Then press either the up or down arrow key to toggle between the F or C designation.

**STEP 2** Press the **SET** key again to access the set point. The LCD will display the current setpoint and the **S1** indicator will be blinking on and off to indicate that the control is in the set point mode. Then press either the up key to increase or the down key to decrease the setpoint to the desired temperature.

**STEP 3** Press the **SET** key again to access the differential. The LCD will display the current differential and the **DIF1** indicator will be blinking on and off to indicate that the control is in the differential mode. Then press the up key to increase or the down key to decrease the differential to the desired setting.

**STEP 4** Press the **SET** key again to access the cooling or heating mode. The LCD will display the current mode, either **C1** for cooling or **H1** for heating. Then press either the up or down key to toggle between the **C1** or **H1** designation. **(This setting must remain at H1 for proper furnace operation and temperature regulation.)** Press the **SET** key once more and programming is complete.

**NOTE:** The ETC will automatically end programming if no keys are pressed for thirty seconds. Any settings that have been changed on the control will be stored at that point.

Step	Indicator	Description
1	F or C	Fahrenheit or Celsius Scale
2	S1 blinking	Setpoint Temperature
3	DIF1 blinking	Differential Temperature
4	C1/H1	Cooling or Heating Mode

### Troubleshooting Error Messages

Display Message

- E1** Appears when either the up or down key is pressed when not in the programming mode.  
**To correct:** If the E1 message appears even when no keys are being pressed replace the control.
- E2** Appears if the control settings are not properly stored in memory.  
To correct: Re-set all settings. If the display continues to show E2, replace the control.
- EP** Appears when the probe is open, shorted, or sensing a temperature that is out of range  
**To correct:** Check to see if the sensed temperature is out of range. If not, check for probe damage by comparing it to a known ambient temperature between -30°F and 220°F. Replace the control if necessary.
- EE** Appears if the EEPROM data has been corrupted.  
**To correct:** This condition can not be field repaired. Replace the control.
- CL** Appears if calibration mode has been entered.  
**To correct:** Remove power to the control for at least five seconds. Reapply power. If the CL message still appears, replace the control

### Specifications

Input Voltage:	120 or 208/240 VAC (24 VAC optional), 50/60 Hz
Temperature Range:	30°F to 220°F
Differential Range:	1°F to 30°
Sensor:	Thermistor, 1.94 in. Long x .025in. Dia. with 8 ft. cable
Power Consumption:	120/208/240 VAC: 100 Milliamps 24 VAC: 2-6 VA

# Electronic Timer Control and Settings

## Description

The electronic timer uses the fan to inject air into the firebox in set intervals. This helps to keep the coal bed alive during periods of idle. **The Timer is factory set to off and can be programmed to turn on, if necessary.** Different grades of coal will burn differently so it may be necessary to try some different settings until an optimal setting is achieved.

## Programming the timer

The timer can be set using the two timing dials and the dip switch settings.

- The image below shows the timer using settings of one hour off and one minute on.

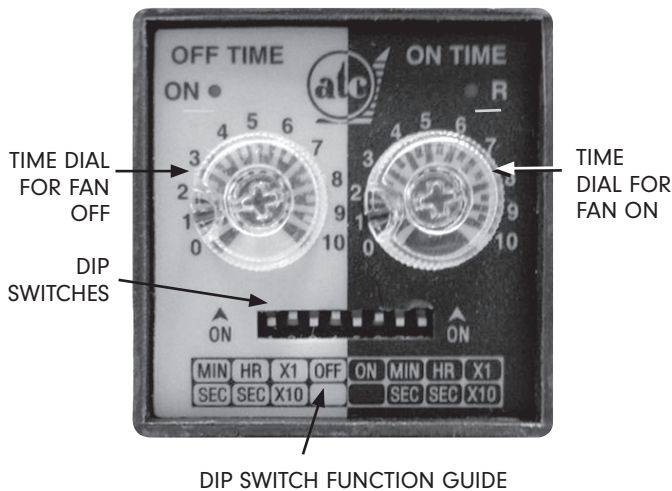

- The OFF TIME or yellow side of the timer will control the how long the fan will be off for
- The ON TIME or black side of the timer will control how long the fan will be on for
- Make sure that the 4th DIP switch is flipped up. This will ensure that the timer will start in an "off" position.
- Make sure that the 5th DIP switch is turned down. This will make the control function in an OFF/ON cycle.

**The OFF Timer** can be set to run in hours, minutes or seconds. The first two DIP switches will control what the time setting will be.

**To set the OFF TIME to hours** (recommended)

- The first DIP switch must be turned down
- The second DIP switch must be turned up

**To set the OFF TIME to Minutes**

- The first DIP switch must be turned up
- The second DIP switch must be turned down

**To set the OFF TIME to seconds**

- Both DIP switches must be turned down

- The 3rd DIP switch controls the timer settings. If it is set to the X1 or up setting it will count in 1/10 fractions instead of whole hours, minutes or seconds.
- The 3rd DIP switch must be set to the X10 or in the down position. This sets the timer in complete hours, minutes or seconds.

**The ON Timer** can be set to run in hours, minutes or seconds. The 6th and 7th DIP switches will control what the time setting will be.

**To set the ON TIME to hours**

- The 6th DIP switch must be turned down
- The 7th DIP switch must be turned up

**To set the ON TIME to Minutes** (recommended)

- The 6th DIP switch must be turned up
- The 7th DIP switch must be turned down

**To set the ON TIME to seconds**

- Both the 6th and 7th DIP switches must be turned down

- The 8th DIP switch must be set to the X10 or in the down position. This sets the timer in complete hours, minutes or seconds.

- The 8th DIP switch controls the timer settings. If it is set to the X1 or up setting it will count in 1/10 fractions instead of whole hours, minutes and seconds.

# Unit Footprints

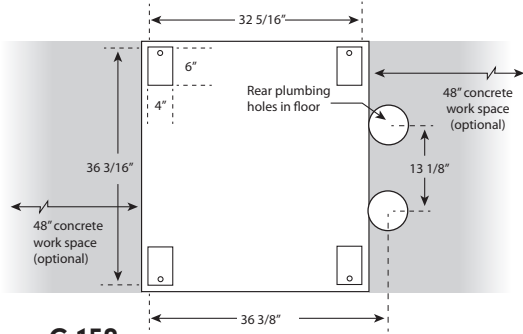

**C-150**

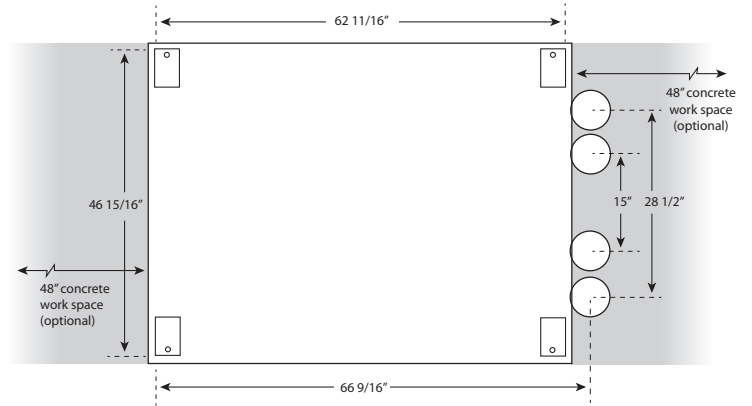

**C-500**

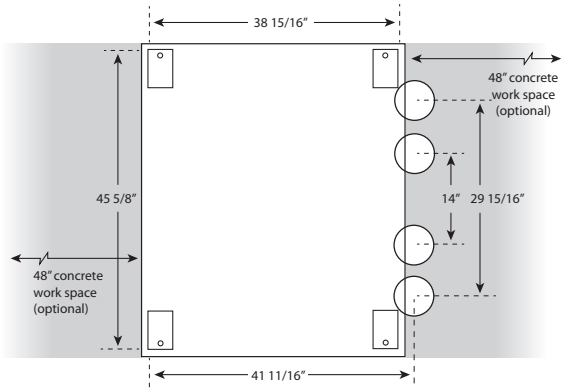

**C-250**

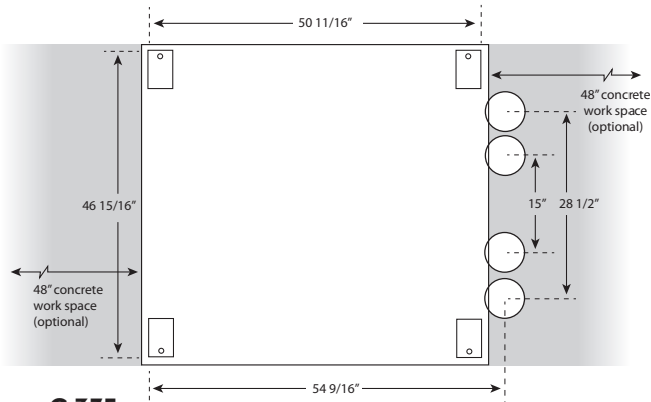

**C-375**

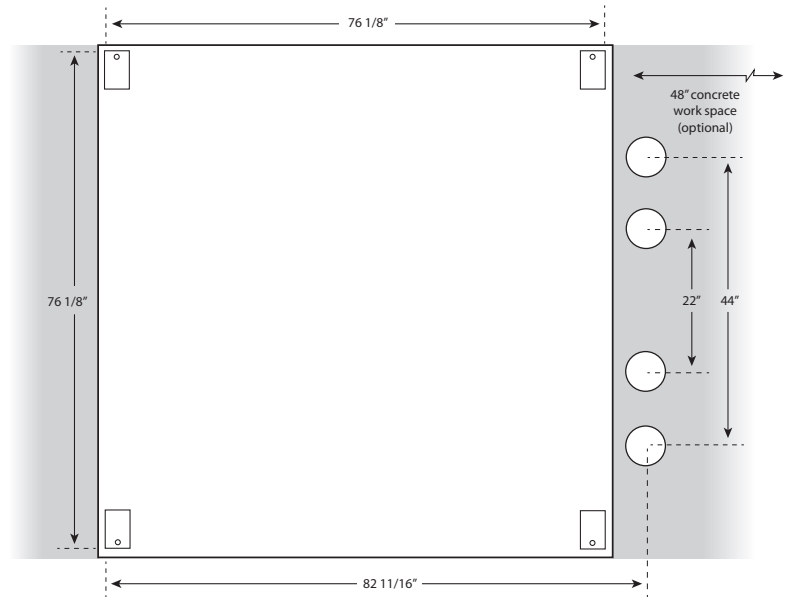

**C-800**

## REPLACEMENT COMPONENTS LIST

Below is a list of furnace components with part numbers that may need to be replaced from time to time. As part of your warranty with Heatmaster<sup>SS</sup> these components are covered under warranty for the 1 year. These components are available through your dealer.

<b>Part Manufacturer's</b>	<b>Part #</b>
20 Amp Light Up Rocker Switch	CRE22F2BBRLE
Dayton 1TDP7 Fan	1TDP7
Dayton 1TDR3 Fan	1TDR3
White-Rodgers Fixed Setting Snap Disc Limit Control	3L01-190
Dormeyer 4x240 Solenoid	2005-M-1
Selkirk 18" x 6" Stainless Steel Double Wall Insulated Chimney	206018U
Selkirk 6" Single Wall to Double Wall Chimney Adapter	709406
Selkirk 18" x 8" Stainless Steel Double Wall Insulated Chimney	208018U
Selkirk 8" Single Wall to Double Wall Chimney Adapter	0709408
Ranco Electronic Temperature Controller	ETC-111000
Coal Timer	422AR-100-S-0-X







**HeatMaster<sup>SS</sup>**  
Tough on Winter, Easy on You

HeatMaster<sup>SS</sup> carries a full line of high quality parts for your furnace including pumps, fittings and heat exchangers. For more information on our parts or to arrange product installation please contact your local HeatMaster<sup>SS</sup> dealer.

**HeatMaster<sup>SS</sup>**

Box 158

Winkler, Manitoba, Canada

R6W 4A5

Phone: (204) 325-9792

Fax: (204) 325-9803

Toll Free: 1-877-325-9792

Email: [info@heatmasterss.com](mailto:info@heatmasterss.com)

**[heatmasterss.com](http://heatmasterss.com)**